

# Kawasaki Robot CX series

Large payload robots - up to 210 kg

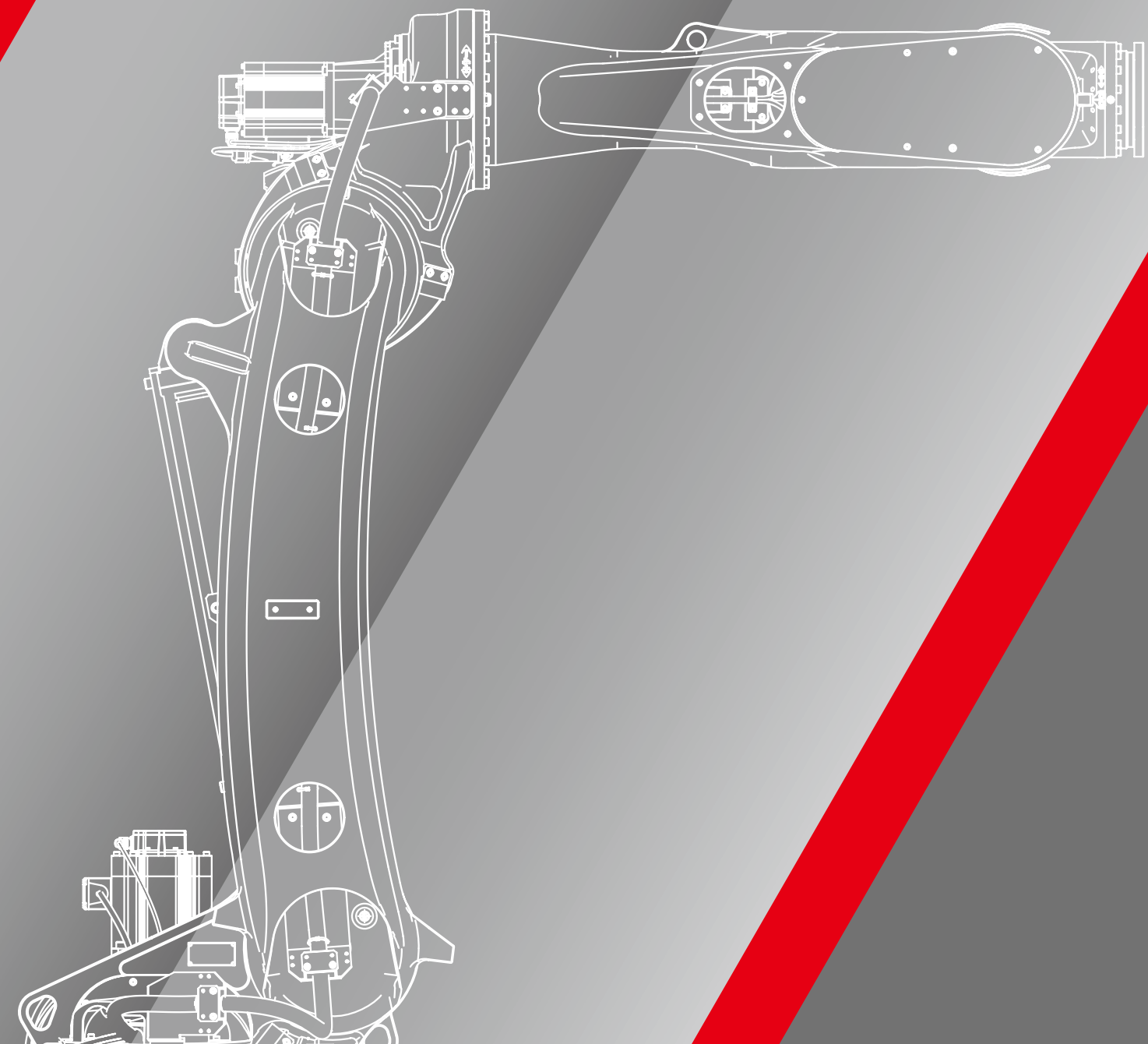

## Kawasaki Heavy Industries, Ltd.

### ROBOT DIVISION

#### Tokyo Head Office/Robot Division

1-14-5, Kaigan, Minato-ku, Tokyo 105-8315, Japan  
Phone: +81-3-3435-2501 Fax: +81-3-3437-9880

#### Akashi Works/Robot Division

1-1, Kawasaki-cho, Akashi, Hyogo 673-8666, Japan  
Phone: +81-78-921-2946 Fax: +81-78-923-6548

### Global Network

#### Kawasaki Robotics (USA), Inc.

28140 Lakeview Drive, Wixom, MI 48393, U.S.A.  
Phone: +1-248-446-4100 Fax: +1-248-446-4200

#### Kawasaki Robotics (UK) Ltd.

Unit 4 Easter Court, Europa Boulevard, Westbrook Warrington  
Cheshire, WA5 7ZB, United Kingdom  
Phone: +44-1925-71-3000 Fax: +44-1925-71-3001

#### Kawasaki Robotics GmbH

Im Taubental 32, 41468 Neuss, Germany  
Phone: +49-2131-34260 Fax: +49-2131-3426-22

#### Kawasaki Robotics Korea, Ltd.

43, Namdong-daero 215beon-gil, Namdong-gu, Incheon, 21633,  
Korea  
Phone: +82-32-821-6941 Fax: +82-32-821-6947

#### Kawasaki Robotics (Tianjin) Co., Ltd.

1-2/F, Building 6, No.19 Xinhuan Road, TEDA, China  
Phone: +86-22-5983-1888 Fax: +86-22-5983-1889

#### Kawasaki Motors Enterprise (Thailand) Co., Ltd.

(Rayong Robot Center)  
119/10 Moo 4 T.Pluak Daeng, A.Pluak Daeng, Rayong 21140  
Thailand  
Phone: +66-38-955-040-58 Fax: +66-38-955-145

<https://robotics.kawasaki.com/>

## Kawasaki Robot

### CAUTIONS TO BE TAKEN TO ENSURE SAFETY

- For those persons involved with the operation / service of your system, including Kawasaki Robot, they must strictly observe all safety regulations at all times. They should carefully read the Manuals and other related safety documents.
- Products described in this catalogue are general industrial robots. Therefore, if a customer wishes to use the Robot for special purposes, which might endanger operators or if the Robot has any problems, please contact us. We will be pleased to help you.
- Be careful as Photographs illustrated in this catalogue are frequently taken after removing safety fences and other safety devices stipulated in the safety regulations from the Robot operation system.



ISO certified in Akashi Works and Nishi-Kobe Works.

# Kawasaki's latest advances in technology deliver increased robot motion speed and range.

The general purpose CX series robots offer a large payload capacity and feature a robust, yet lightweight, hollow arm and a new smaller sized universal controller. The series high-speed and slim arm design was developed to suit a wide range of applications, from material handling to spot welding.

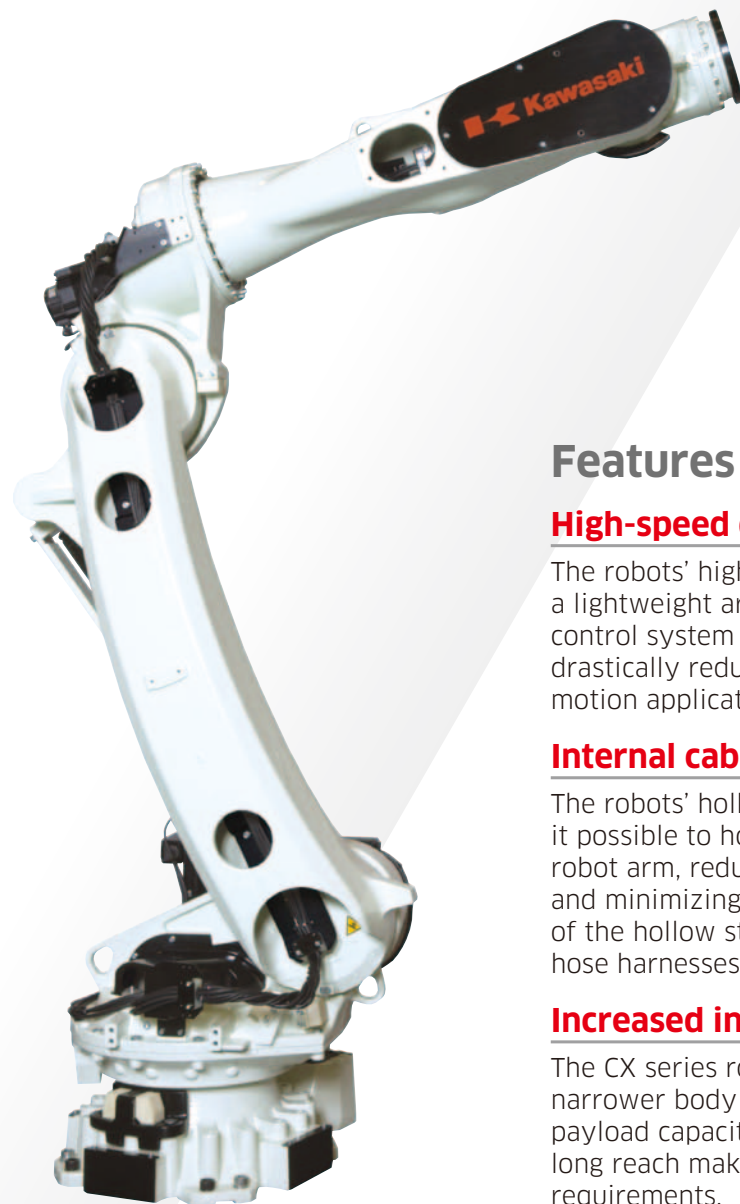

## Features

### High-speed operation

The robots' high-speed operation is achieved by combining a lightweight arm construction with the latest vibration control system and a maximum-speed-focused setting. This drastically reduces cycle time, especially in long stroke motion applications such as material handling.

### Internal cable and hose harnesses

The robots' hollow upper arm and base construction makes it possible to house cable and hose harnesses within the robot arm, reducing the amount of work space required and minimizing potential interference. The large diameter of the hollow structure makes it easier to retrofit cable and hose harnesses or service the robot.

### Increased installation flexibility

The CX series robots have a much smaller footprint and narrower body compared to other robots with similar payload capacity. These robots space saving design and long reach make it possible to satisfy most robot layout requirements.

## Standard specifications

		CX110L	CX165L	CX210L
Type		Articulated robot		
Degree of freedom (axes)		6		
Max. Payload (kg)		110	165	210
Max. Reach (mm)		2,699	2,699	2,699
Repeatability (mm) *1		±0.06	±0.06	±0.06
Motion Range (°)	Arm rotation (JT1)	±160	±160	±160
	Arm out-in (JT2)	+80 - -60	+80 - -60	+80 - -60
	Arm down-up (JT3)	+95 - -75	+95 - -75	+95 - -75
	Wrist swivel (JT4)	±210	±210	±210
	Wrist bend (JT5)	±120	±120	±120
	Wrist twist (JT6)	±360	±360	±360
Max. Speed (°/s)	Arm rotation (JT1)	140	130	125
	Arm out-in (JT2)	135	125	115
	Arm down-up (JT3)	135	125	115
	Wrist swivel (JT4)	200	180	155
	Wrist bend (JT5)	200	180	160
	Wrist twist (JT6)	300	280	220
Moment (N·m)	Wrist swivel (JT4)	830	952	1,370
	Wrist bend (JT5)	830	952	1,370
	Wrist twist (JT6)	441	550	700
Moment of Inertia (kg·m <sup>2</sup> )	Wrist swivel (JT4)	85	99	199.8
	Wrist bend (JT5)	85	99	199.8
	Wrist twist (JT6)	45	49.5	154.9
Mass (kg)		870	870	870
Body color		Munsell 10GY9/1 equivalent		
Mounting		Floor		
Environmental Condition	Ambient temperature (°C)	0 - 45		
	Relative humidity (%)	35 - 85 (No dew, nor frost allowed)		
Power requirements (kVA) *2		7.5		
Degree of protection		IP54		
Controller		E02		

\*1 : conforms to ISO9283

\*2 : depends on the payload and motion patterns

CX110L

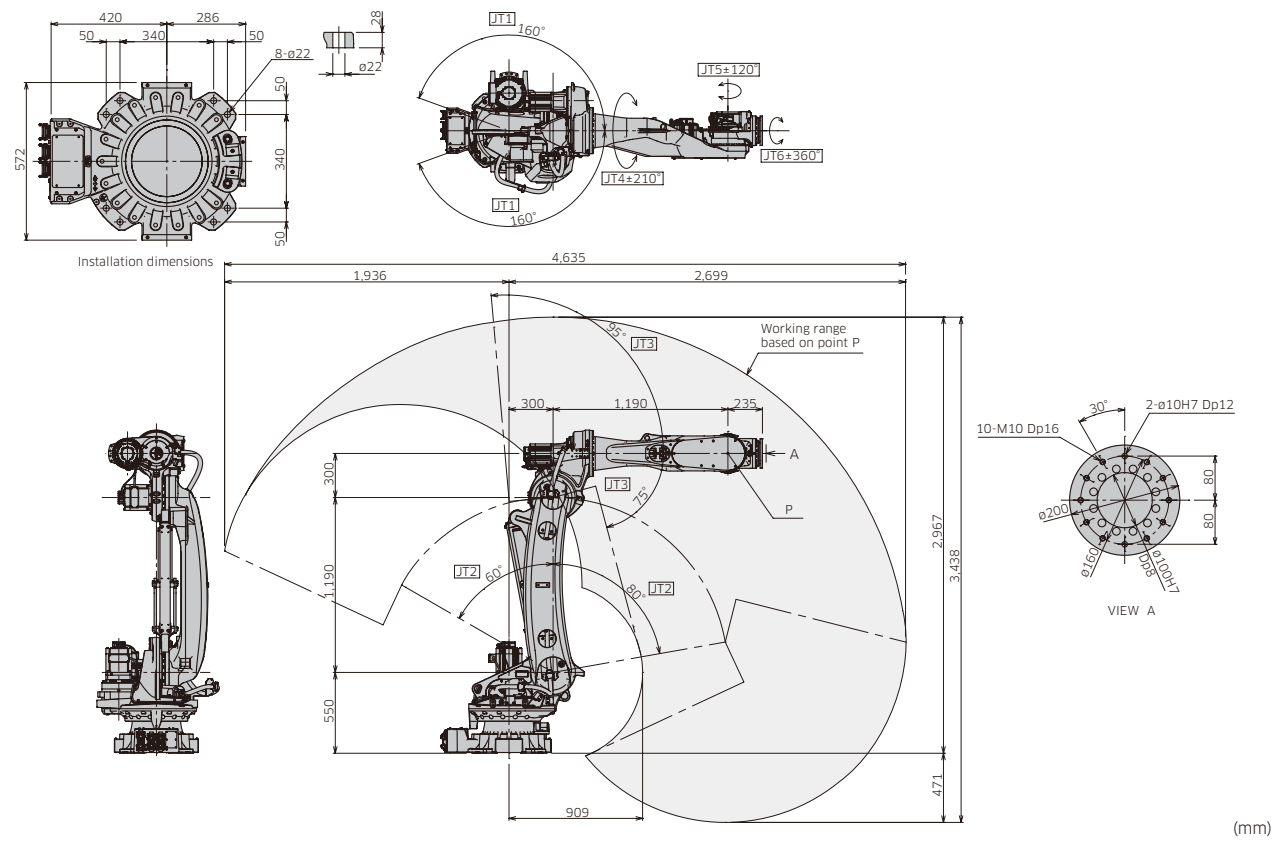

(mm)

CX210L

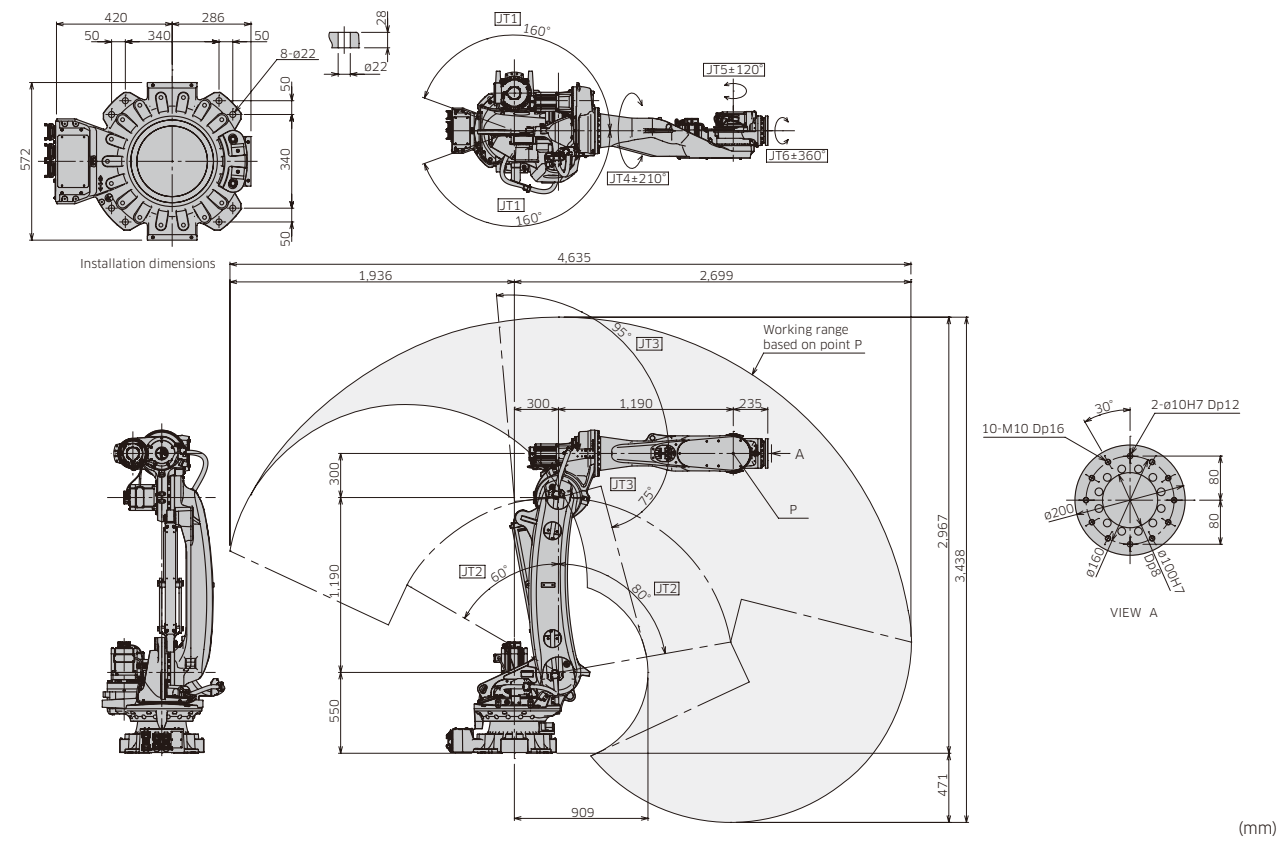

(mm)

CX165L

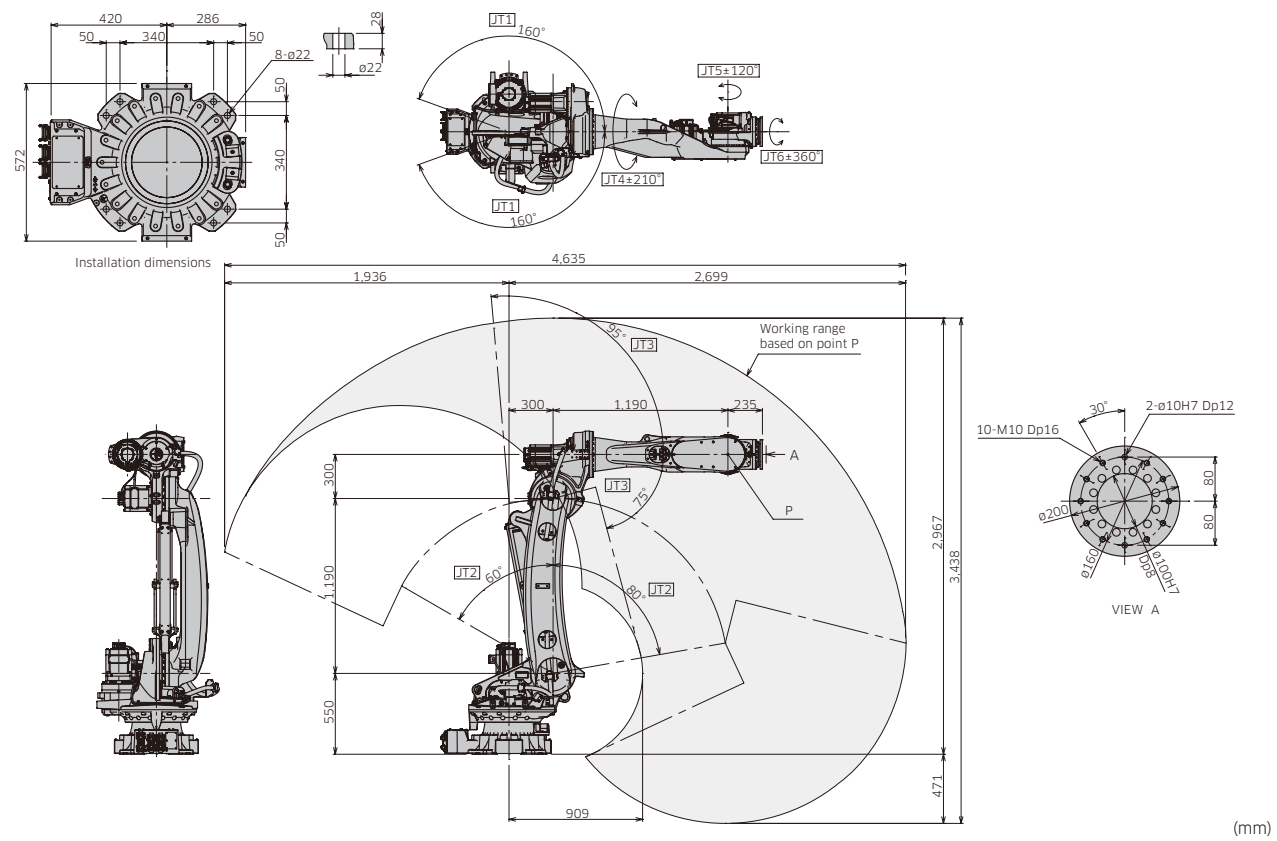

(mm)

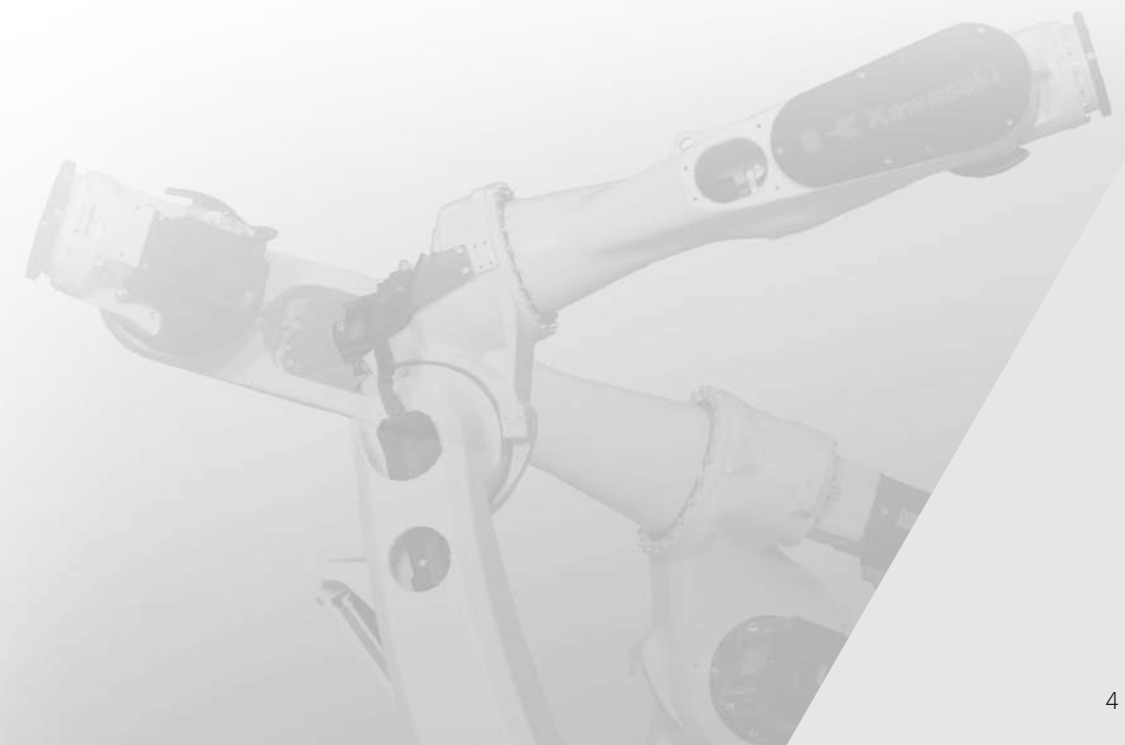



# E series

The E-Controller, with unprecedented quality and compact size, was created in response to customer demand. Kawasaki's collaboration of past achievements and experience has led to the development of the most technically advanced controller available. This industry leading design provides increased performance and easy operation that exceeds expectations.



\*Option

## Features

### Compact

Small footprint of the E controller makes it easy to achieve high-density layouts. And overall volume has been reduced greatly compared with the previous model. As a result, an upright-position installation or stacked installation is possible, in order to save installation space.

### User-friendly operation system

The operation system has now fully developed into a more user-friendly design. The operator can turn on the motors and activate the cycle start all from the teach pendant, thereby realizing a more convenient system control. The two information screens can be displayed simultaneously, enabling the operator to view different types of information easily (for example, positional and signal information).

### Abundance of functions

The large variety of unique functions makes it possible to support a wide range of applications. These functions can be combined and easily configured within a system to suit a particular application. Likewise, the built-in Kawasaki "AS Language" provides sophisticated robot motion and sequence controls.

### Incorporating the latest technologies

The enhanced CPU capacity allows for more accurate trajectory control, faster program execution, and quicker saving and loading of files, and countless other advantages. In addition, the memory has been expanded to answer the need for higher program storage capacity. A USB port is equipped as a external storage conduit.

### Easier maintenance

With modular components and fewer cables, Kawasaki has developed a controller that is compact and easy to maintain. A host of maintenance functions are available, including the DIAG function for self-diagnostics, a maintenance support function that can handle not only hardware errors but also application errors. In addition to the DIAG function, there are other additional functions, such as a Web server that enables engineers to perform remote diagnostics.

### Highly expandable

This is expandable to up to three external axes with additional amplifiers. The system is compatible with a large number of field buses that are used for controlling peripheral devices. Users can combine the Kawasaki KLogic software sequencer function, which can be edited on the teach pendant, with the user-customizable interface panels to create a highly sophisticated system.

## Teach pendant

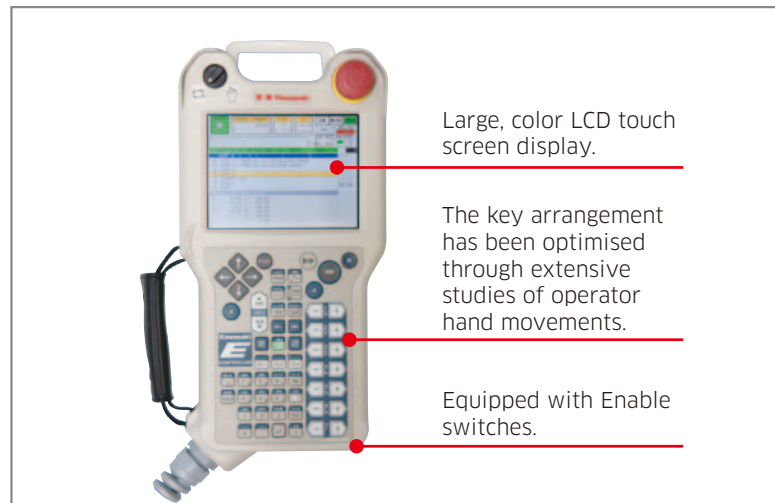

## External view & dimensions

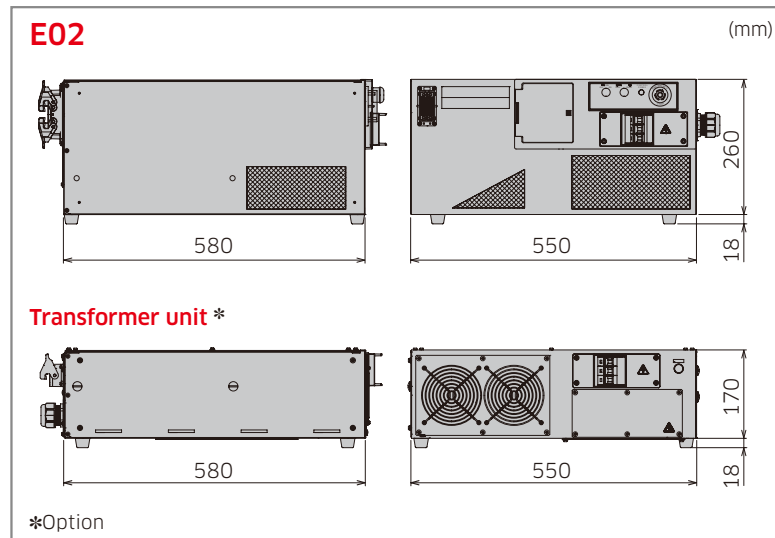

## Specifications

		Standard	Option
		E02	
Dimensions (mm)		W550×D580×H278	Transformer unit: W580×D580×H178
Structure		Enclosed structure / Indirect cooling system	
Number of controlled axes		7	Max. 9
Drive system		Full digital servo system	
Coordinate systems		Joint, Base, Tool	Fixed tool point
Types of motion control		Joint/Linear/Circular Interpolated motion	
Programming		Point to point teaching or language based programming	
Memory capacity (MB)		8	
General purpose signals	External operation	Motor power off, Hold	
	Input (Channels)	32	Max. 96
	Output (Channels)	32	Max. 96
Operation panel		E-Stop switch, teach/repeat switch, control power light (Cycle start, motor-on, hold/run, and error reset are activated from the teach pendant.)	Rapid-feed check mode switch
Cable length	Teach pendant (m)	5	10, 15
	Robot-controller (m)	5	10, 15
Mass (kg)		40	Transformer unit: 45
Power requirements		AC200-220V ±10%, 50/60Hz, 3ø	Transformer unit AC380-415V ±10% or AC440-480V ±10% 50/60Hz, 3ø
		Class-D earth connection (Earth connection dedicated to robots), leakage current: Maximum 100mA	
Environmental condition	Ambient temperature (°C)	0 - 45	
	Relative humidity (%)	35 - 85 (no dew, nor frost allowed)	
Body color		Munsell 10GY9/1 equivalent	
Teach pendant		TFT color LCD display with touch-panel, E-Stop switch, teach lock switch, Enable switch	
Auxiliary storage unit		-	USB Memory
Interface		USB, Ethernet (100BASE-TX), RS-232C	

## System configuration diagram

